

TECHNICAL DATA SHEET

**PLATFORM FOR
SAFETY SKIPS
ACCESS**



1. INTRODUCTION

This platform is designed for safety skips access, used by one person.

General description:

- Aluminum structure 100 x 30 mm
- Anti-slip ribbed aluminum depth 230 mm
- Covering aluminum sheet platform
- Handrail and guardrail Ø 40 mm
- Baseboard height 150 mm
- 2 fixed wheels Ø 200mm at rear
- 2 swivel wheels with brakes Ø 200mm at front

2. REGULATION

This technical data assure the characteristic values stated:

- Complies with the safety requirements of the decree 2004-924

3. COMPLIANCE

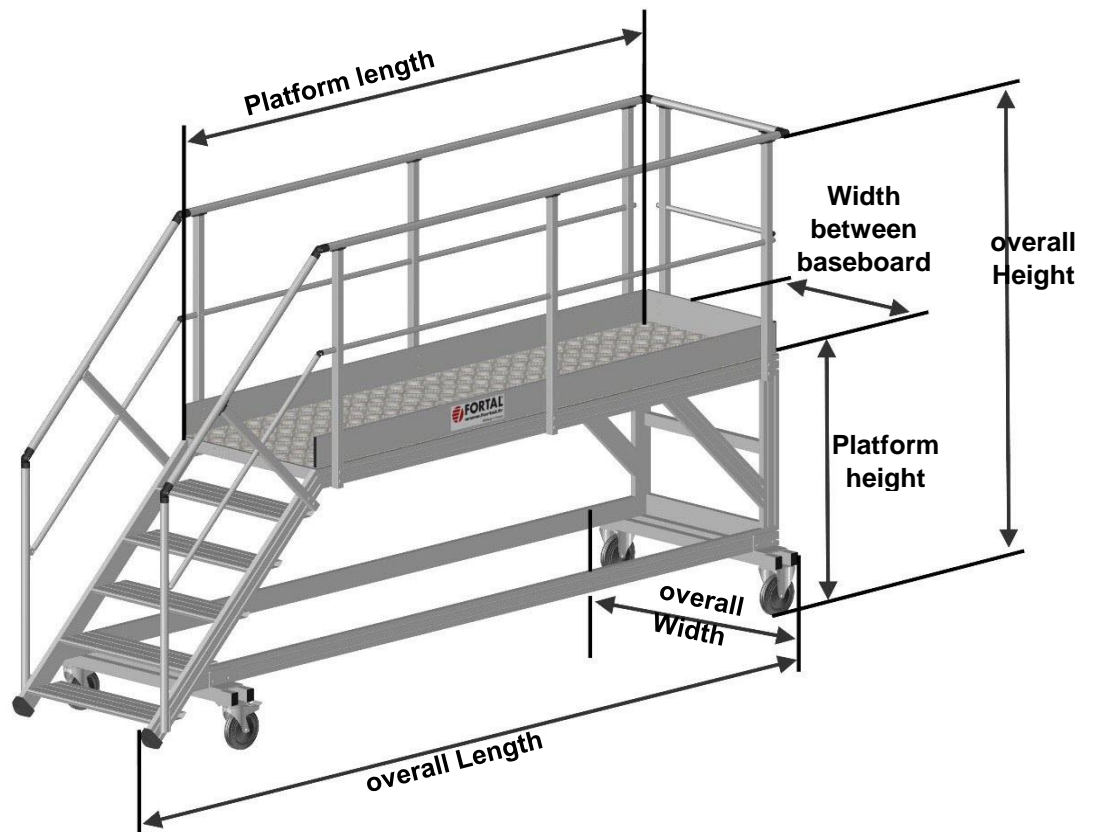

Reference	Description
F801140018	Platform for safety skips access lg.1m
F801140017	Platform for safety skips access lg.2m
F801140014	Platform for safety skips access lg.3m

4. RANGE AND TECHNICAL CHARACTERISTICS

Reference	Number of steps	Platform length (mm)	Platform height H (mm)	Width between baseboard (mm)	Overall width (mm)	Overall length (mm)	Overall height (mm)	Weight (kg)
F801140018	6	1000	1250	826	1170	2170	2360	92
F801140017		2000				3170		121
F801140014		3000				4170		142

Reference F801140018:



Reference F801140017:



Reference F801140014:



5. COMPONENT LIST

Désignation	Rep	Référence
Articulation connection Ø40	1	F191000010
Plug for baseboard	2	A750030029
Plug EAS 60x40	3	A750026040
Articulation connection Ø27	4	F191000015
Smooth plug	5	A750030025
Connection between handrail and pole	6	F191000008
Swivel wheel with brakes Ø200 rubber tyres	7	F030800025
Fixed wheel Ø200 rubber tyres	8	F030800020
Rubber pad 100x30 mm	9	F030800011
Right side guardrail	10	F801140019-001
Left side guardrail	11	F801140019-002
Rear guardrail	12	F801140019-003
Lateral guardrail length 1000	13	F801140018-002
Lateral guardrail length 2000	14	F801140017-001
Lateral guardrail length 3000	15	F801140014-003
Front crossbar + wheels	16	F801140018-001



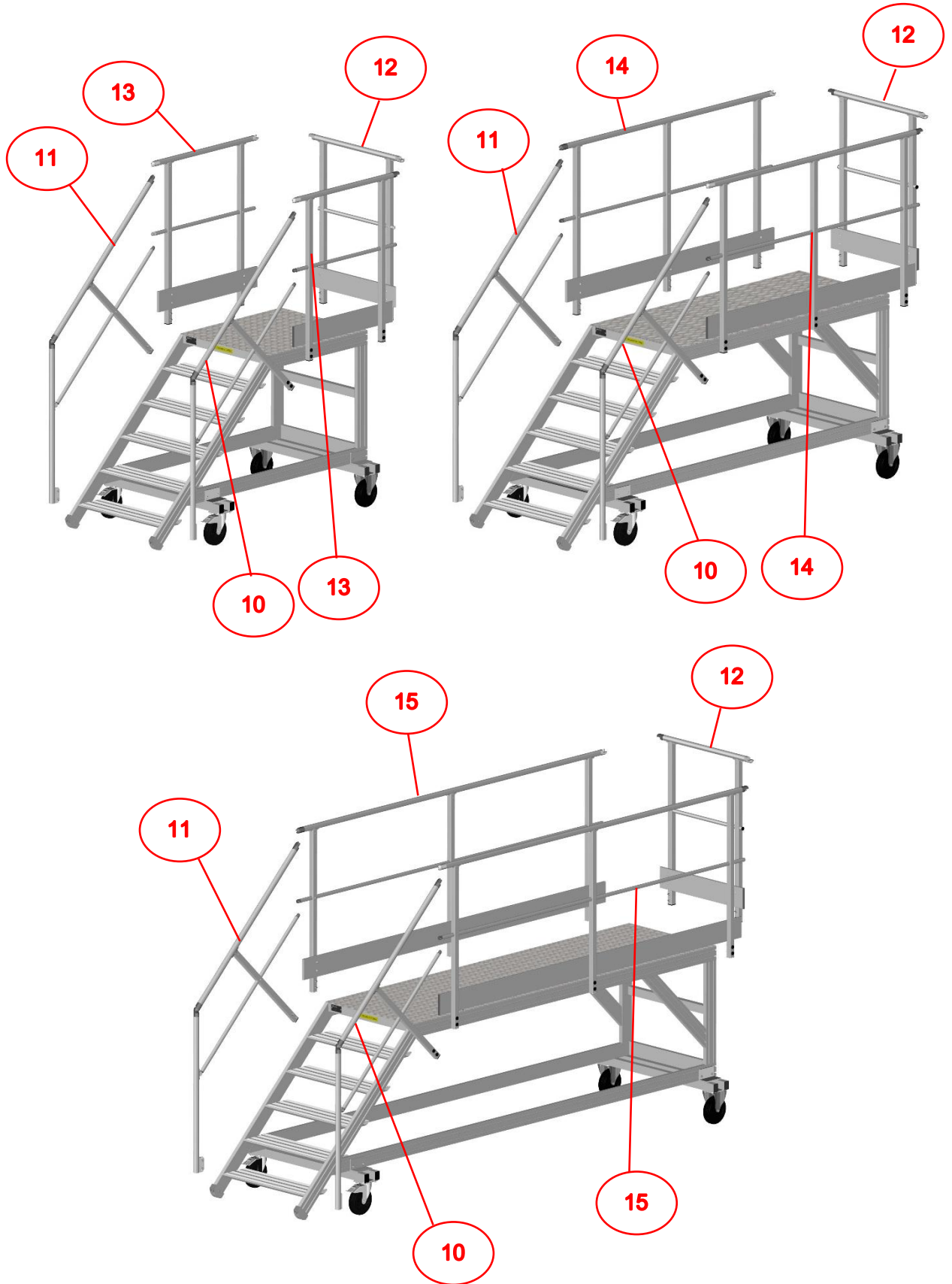

6. OPTIONS

6.1 Lever kit F801140014-002 :

Description (spare part)	Rep	Reference
Stop system for lever	2	R800010006
Swivel wheel Ø125	1	A790070125

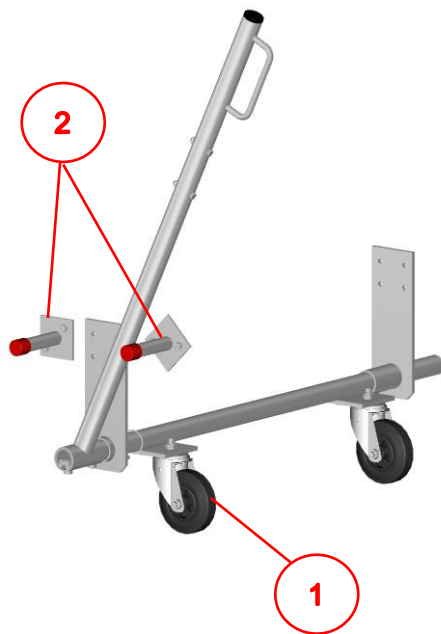

7. SAFETY TIPS

MAXIMUM LOAD CAPACITY: 1 PERSON 150 KG

Before each use of platform, verify by visual inspection the following :

- Good condition of the platform and its accessories
- Wear or lack of pads
- Possible presence of deformations of the elements
- Condition of welds
- Presence of the product identification label (attached to one of the profile)
- For replacement of any spare parts, use only original FORTAL elements

Tips for optimal use :

- Surfaces of use must be flat and not slippery
- Use suitable footwear providing safe support
- Never climb on the guardrail

8. WARRANTY

FORTAL guarantees its own manufactured products (excepting specific clauses accepted by the customer and FORTAL) for a period of 2 years from the delivery date (date given on the delivery slip) against all manufacturing defects, except for:

- Labour costs and travelling costs
- Wear and tear due to impacts, a lack of maintenance, shocks, etc.
- Use in inappropriate conditions or conditions that do not comply with those defined herein or installations that do not comply with the user installation instructions.

Any other compensation is formally excluded from the warranty, including operating loss, damage incurred and any prejudice whatsoever subsequent to using our manufactured products.

Any modification, repair or replacement of parts during the warranty period does not extend the period of cover.

Should our manufactured products be modified outside our production site without our prior written agreement, FORTAL's liability cannot be incurred.